

**Lighting Standards**

**Iowa  
High School  
Athletic  
Association**



Adopted 09/17

# TABLE OF CONTENTS

Standards of Lighting .....	3
I. Recommended Minimum Standards.....	3
PART 1 – GENERAL .....	3
1.1 LIGHTING PERFORMANCE.....	3
1.2 ENVIRONMENTAL LIGHT CONTROL.....	5
1.3 MEASUREMENT OF LIGHT .....	5
1.4 LIFE-CYCLE COSTS.....	5
1.5 CONTROL AND MONITORING SYSTEM.....	6
1.6 WARRANTY AND GUARANTEE .....	6
PART 2 – PRODUCT.....	7
2.1 LIGHTING SYSTEM CONSTRUCTION.....	7
2.2 STRUCTURAL PARAMETERS.....	9
2.3 ELECTRICAL PARAMETERS .....	9
PART 3-EXECUTION .....	10
3.1 FIELD QUALITY CONTROL .....	10
II. Desirable Features .....	11
4.1 WARRANTY .....	11
4.2 TV QUALITY LIGHTING.....	11
4.3 DIMMING.....	11
4.4 ENTERTAINMENT PACKAGES/ LIGHT SHOWS.....	12
4.5 AUXILIARY BRACKETS .....	12
4.6 SERVICING OPTIONS . .....	12
4.7 FIELD PERIMETER LIGHTING.....	12
4.8 EMERGENCY LIGHTING FOR SPECTATOR SEATING AREA .....	12
LIFE-CYCLE OPERATING COST EVALUATION.....	13
SUBMITTAL INFORMATION.....	14
Appendix .....	15
Typical Facility Information .....	15
Light Level Grid Point Layouts .....	15
Pole Location Diagrams.....	18
Lighting Performance Testing.....	31
Glossary.....	40

# Standards of Lighting

The following guidelines are recommended by the Iowa High School Athletic Association. These standards apply to the lighting of all high school athletic activities sponsored by the IHSAA or its member schools.

These standards incorporate the most current data available regarding the lighting, electrical and structural issues that apply to installation of a safer, more effective lighting system.

The standards are divided into recommended minimums and desirable features. The minimums establish criteria important to safe conduct of IHSAA activities and include evaluation of operating costs over the expected life of the lighting system. Desirable features are established to give added values where appropriate for a facility's needs.

## **I. Recommended Minimum Standards**

These minimum standards are recommended for all lighting installations after the date of adoption of these standards. Any modification in existing lighting systems after this date should be done so as to result in a lighting system in compliance with these standards. To be in compliance, a system must meet all recommended minimum standards.

### **PART 1 – GENERAL**

#### **1.1 LIGHTING PERFORMANCE**

The lighting system shall provide target illuminance level over the guaranteed lifetime of the system's operation. The IES "Recommended Practice for Sports and Recreational Area Lighting" RP-6-20 provides design criteria for sports facilities.

##### **A. Preferred LED Technology**

LED is the preferred lighting system technology due to energy efficiency, increased lifespan, reduced maintenance, and minimal light depreciation over the operating life of a typical sportslighting system.

LEDs can be manufactured with a broad range of correlated color temperatures (CCT). Currently, the most efficient LEDs for sportslighting are around 5700K.

##### **B. Sustaining target light levels over time**

Lighting manufacturers will provide a guarantee that light levels will be sustained over the life of the system.

Additionally, manufacturers will provide lumen maintenance data of the luminaires used per TM-21-11, and will incorporate the lumen maintenance projections into the lighting designs to ensure target light levels are achieved throughout the guaranteed period of the system. Per IES guidelines, lumen maintenance hours should be reported based on the 6X multiplier of testing hours.

##### **C. Sustaining target light levels over time**

Playing surfaces shall be lit to a target light level and uniformity as specified in the following chart. Lighting calculations shall be developed and lighting manufacturers should provide drawings showing the horizontal footcandle quantity at each point of measurement on the field. The drawings should indicate the target light level, and initial light level for prior technology HID systems. They should also contain any light loss factors applied if applicable.

Area of Lighting	Target Light Levels	Maximum to Minimum Uniformity Ratio	Uniformity Gradient	Coefficient of Variation
Baseball/Softball	50 fc Infield 30 fc Outfield	2:1 Infield 2.5:1 Outfield	1.5	0.17
Football/Soccer/Lacrosse/Field Hockey/Rugby Less than 2000 spectators Up to 5000 spectators More than 5000 spectators	30 fc 50fc 100fc	2.5:1 2:1 1.7:1	1.5	0.21
Gymnasium / Basketball No spectators With spectators	50 fc 80 fc	3:1 2.5:1	2.0 1.5	0.25 0.21
Natoriums	Consult an experienced lighting manufacturer or lighting specialist			
Tennis	50 fc	2:1	1.5	0.17
Track Competitive Use General Use (Walking)	30 fc 5 fc	5:1 N/A	2.0	0.30
Combination / Multipurpose	Highest minimum for activites played on the field	Lowest minimum for activites played on the field	Lowest minimum for activites played on the field	Lowest minimum for activites played on the field

#### D. Maximum to Minimum Uniformity Ratio

The ratio of highest illuminance value to lowest illuminance value should not exceed the value specified.

#### E. Uniformity Gradient

The ratio between any two adjacent illuminance values on a field should not exceed the value specified.

#### F. Coefficient of Variation

The maximum ratio of the standard deviation for all of the footcandle values to the mean should not exceed the value specified.

#### G. Glare for Participants

To achieve placement of lights in positions that enhance playability, pole locations and luminaire placements should be as shown on the layouts in the appendix. Luminaires should be selected that have glare control technology. This technology may include internal and external visors - either over the individual LED packages inside the luminaire, or on the luminaire itself, or both. Not all luminaire have equal glare control performance. Select a lighting manufacturer that has proven glare control technology.

#### H. Aerial Lighting

For aerial sports, such as baseball, adequate illumination must be provided above the field in order to see the ball in flight. It is recommended that a lighting analysis be performed above the field of play to evaluate the visibility of the ball over its typical trajectory to ensure the participants will adequately see the ball. For example, calculation planes can be added at various elevations up to the maximum anticipated height for the level of play. Offsite calculations should also be included to understand any effects beyond the field of play.

## **1.2 ENVIRONMENTAL LIGHT CONTROL**

Many facilities are located near residential properties or roadways, creating the possibility of spill and glare onto adjoining properties. Consideration should be given to this issue during the initial lighting design stage to minimize this effect. Some communities are implementing ordinances designed to minimize light pollution. Contact your local planning committee or zoning board.

The lighting equipment manufacturer should assess both spill and glare at all areas of concerns on adjacent properties. Manufacturer should provide both an illumination summary for spill light and an environmental glare impact summary for areas of concern. The environmental glare impact summary should show the maximum candela an observer would see when facing the brightest light source from any direction. For areas of concern, a good guideline is to keep glare from the brightest source below 7,500 candela at 150 feet. This is equal to roughly half what a low beam car headlight would be. Measurements are taken at the point of concern, at 60 inches above the ground.

Check local ordinances for light control restrictions.

Do not hesitate to investigate a manufacturer's reputation, abilities, and past experiences in working with local authorities and private property owners regarding glare and spill issues.

## **1.3 MEASUREMENT OF LIGHT**

### **A. Area of Light Quantity**

The areas for which measurements are to be taken and the points of measurement within that area are shown in the appendix. It is important that measurements be taken at all of the points to meaningfully establish that the standards for quantity and quality are being met for the facility.

### **B. Methods of Measuring Light Quantity**

The light sensing surface of the light meter should be held 36 inches above the playing surface with the sensing surface horizontal so that it detects light coming downward to the sensing surface from all directions around the ballfield. Testing equipment for measurement of light should be a cosine and color-corrected light meter regularly calibrated in footcandles.

### **C. Methods for Measure Glare (Candela)**

The light sensing surface of the Luminous Intensity Meter should be held 60 inches above the playing surface with the aperture adjusted so that it detects luminous intensity from the brightest luminaire on each light bank.

## **1.4 LIFE-CYCLE COSTS**

Because the efficiency of lighting systems currently available can vary greatly, a life-cycle operating cost analysis should be considered when evaluating lighting systems. Owners should expect a quality lighting system to last a minimum of 25 years.

These standards provide a Life-Cycle Operating Cost Evaluation form to assist with the process. Items that should be included are energy consumption based upon the facility's expected usage, cost for group and spot relamping (for HID systems) and maintenance, and any additional savings in energy or labor cost provided by automated on/off control systems.

Contract price and life-cycle operating cost should both be considered in determining a lighting manufacturer for the project.

## **1.5 CONTROL AND MONITORING SYSTEM**

A remote control and monitoring system will provide ease of operation and management for your facility. Manufacturers providing systems with a 25 year warranty will utilize this system to ensure your lighting performs as required.

### **A. Remote Monitoring**

The system shall monitor lighting performance and notify manufacturer if individual luminaire outage is detected so that appropriate maintenance can be scheduled. The manufacturer shall notify the owner of outages within 24 hours, or the next business day. The controller shall determine switch position (Manual or Auto) and contactor status (open or closed).

### **B. Remote Lighting Control**

The system shall allow owner and users with a security code to schedule on/off system operation via a web site, phone, fax, or email up to 10 years in advance. Manufacturer shall provide and maintain a two-way TCP/IP communication link. Trained staff shall be available 24/7 to provide scheduling support and assist with reporting needs.

The owner may assign various security levels to schedulers by function and/or fields. This function must be flexible to allow a range of privileges, such as full scheduling capabilities for all fields, to only having permission to execute "early off" commands by phone.

Control unit shall accept and store 7-day schedules, be protected against memory loss during power outages, and shall reboot once power is regained and execute any commands that would have occurred during outage.

### **C. Contactor Control of Luminaires**

The system shall allow for contactor control of lighting to circuits. Lighting systems that use a driver mode to dim-to-zero to turn off lights (drivers powered on but zero output to luminaires) should not be used, due to increased wear on drivers, and unnecessary driver power consumption while lights are turned off.

### **D. Management Tools**

Manufacturers shall provide a web-based database of actual field usage and provide reports by facility and user group.

### **E. Communication Costs**

Manufacturers shall include communication costs for operating the controls and monitoring system for a period of 25 years.

### **F. Cabinet Construction**

Control and Monitoring Cabinet shall be constructed of aluminum and rated NEMA Type 4. Cabinet shall contain custom-configured contactor modules for 30, 60, and 100 amps, labeled to match field diagrams and electrical design. Manual Off-On-Auto selector switches shall be provided.

## **1.6 WARRANTY AND GUARANTEE**

### **A. LED**

New generation technology comes with warranty periods of up to 25 years and includes guaranteed light levels, parts, labor, lamp replacements, energy usage, monitoring and control services, spill light control, and structural integrity.

## **B. Fulfillment**

The manufacturer should have financial reserves to assure fulfillment of the warranty for the full term. It is highly recommended you consider all-inclusive warranties to limit your school's future exposure to escalating costs and maintenance hassles.

## **PART 2 – PRODUCT**

### **2.1 LIGHTING SYSTEM CONSTRUCTION**

A lighting system should consist of lighting, electrical, and structural components designed to work together as a system that is durable and provides safety features.

#### **A. Outdoor lighting systems should consist of the following:**

1. Galvanized steel poles and crossarm assembly. Wood poles or direct burial steel poles are not recommended.
2. Pre-stressed concrete base embedded in concrete backfill or a poured-in-place foundation containing reinforcing steel cured a minimum of 28 days before any stress load is applied.
3. All drivers and supporting electrical equipment mounted remotely in aluminum enclosures approximately 10' above grade. The enclosures shall include driver, controller, and fusing for each luminaire. Safety disconnect and surge protection per circuit for each pole structure must be located in the enclosure.
4. Wire harness complete with an abrasion protection sleeve, strain relief, and plug-in connections for fast, trouble-free installation.

#### **B. Retrofit outdoor sports lighting systems:**

By retrofitting new LED technology onto an existing sportslighting structure and reusing electrical supply wiring, you can achieve quality lighting results with state of the art technology while reducing costs often associated with entirely new outdoor lighting systems. A retrofit lighting system should consist of the following:

1. Poletop luminaire assembly that includes new crossarms, factory-aimed luminaires, and a method of attachment to existing poles.
2. Electrical components enclosure and wire harnesses as described in the following sections.
3. Inspections for existing equipment
  - a. Structure – the structure must be evaluated to ensure that it meets the requirements of the new luminaire load, and current building code. Often LED luminaires are much heavier than HID luminaires and have increased windloads. It may not be possible to replace luminaires at a 1:1 replacement ratio. Consult the pole manufacturer, if possible.
  - b. Electrical Supply – the electrical supply wiring should be in good condition and sized appropriately for the new loads. Insulation and leakage current tests should be conducted.
  - c. Lighting protection – LED lighting loads can be more sensitive to lightning and other surge events than older HID lighting loads. Verify that the lightning grounding of existing structure meets current electrical code. Ground resistance should not exceed 25 ohms. If the condition of the lightning down conductor cannot be determined (e.g. encased in a concrete pole), it is recommended to supply new.



#### 4. Life-cycle costs

Because the efficiency of lighting systems currently available can vary greatly, a life-cycle operating cost analysis should be considered when evaluating lighting systems. Owners should expect a quality lighting system to last a minimum of 25 years.

These standards provide a Life-Cycle Operating Cost Evaluation form to assist with the process. Items that should be included are energy consumption based upon the facility's expected usage, cost for group and spot relamping (for HID systems) and maintenance, and any additional savings in energy or labor cost provided by automated on/off control systems.

Contract price and life-cycle operating cost should both be considered in determining a lighting manufacturer for the project.

#### **C. Interior sports lighting systems:**

1. All luminaires shall consist of a die-cast aluminum heatsink for heat dissipation, and a shatter-resistant glare reduction visor.
2. If driver is integral in luminaire, it should have a dedicated heatsink for longevity

#### **D. Manufacturing Requirements**

All components should be designed and manufactured as a system. All luminaires, wire harnesses (if provided), and electrical components enclosures should be factory assembled, aimed, wired, and tested for reduced installation time and trouble-free operation.

#### **E. Durability**

All exposed components should be constructed of corrosion-resistant material and or coated to help prevent corrosion. All exposed steel should be hot-dip galvanized per ASTM A123. All exposed hardware and fasteners should be stainless steel of at least 18-8 grade, passivated and polymer coated to prevent possible galvanic corrosion to adjoining metals. All exposed aluminum should be powder coated with high performance polyester. All exterior reflective inserts should be anodized; coated with a clear, high gloss, durable fluorocarbon; and protected from direct environmental exposure to prevent reflective degradation or corrosion. All wiring should be enclosed within the crossarms, conduit, pole, or electrical components enclosure.

#### **F. Luminaire Alignment**

The sports lighting manufacturer's warranty should include accurate alignment of the luminaires. The current technology of lighting equipment has precise intense beams; the misalignment of individual luminaires by a few degrees can significantly impact the appearance of the field. Misaligned luminaires can also result in undesirable glare for players, spectators, and neighbors.

#### **G. Lightning Protection**

All outdoor structures should be equipped with lightning protection meeting NFPA 780 standards.

#### **H. Safety**

All system assemblies should be UL Listed for the appropriate application.

## **2.2 STRUCTURAL PARAMETERS**

### **A. Location**

Poles should be located as shown on the drawings in the appendix to these standards. Whenever possible, poles should be located outside of fences to avoid causing an obstruction or safety hazard to the participants.

### **B. Foundation Strength**

Project-specific foundation drawings stamped by a registered Iowa structural engineer illustrating that the foundation design is adequate to withstand the forces imposed from the pole, luminaires, and other attachments to prevent the structure from leaning should be provided by the manufacturer.

Recommended foundation types include: direct buried prestressed concrete poles, direct buried prestressed concrete base with a slip fit steel pole shaft, or a poured-in-place concrete foundation with anchor bolts and a base plate galvanized steel pole. It is recommended that all pole bases be of concrete construction in the ground and to a point 18 inches above the ground to avoid corrosive deterioration. Foundations designed with direct embedment steel components are not recommended.

### **C. Support Structure Wind Load Strength**

Poles and other support structures, brackets, arms, bases, anchorages, and foundations shall be determined based on the 50 year mean recurrent isotach wind maps for the appropriate county per the Iowa State Building Code/International Building Code (IBC).

Luminaire, visor, and crossarm shall withstand 150 mph winds and maintain accurate aiming alignment.

### **D. Structural Design**

The stress analysis and safety factor of the poles should conform to AASHTO Standard Specifications for Structural Supports for Highway Signs, Luminaires, and Traffic Signals.

### **E. Soil Conditions**

The design criteria for these specifications are based on soil design parameters as outlined in the geotechnical report. If a geotechnical report is not available, the foundation design can be based on soils that meet or exceed those of a Class 5 material as defined by 2001 IBC, Table 1804.2-I-A.

### **F. Backfill**

Any backfill of excavated soil should be replaced with concrete to ensure adequate compressive strength, which will avoid leaning and misalignment of poles.

## **2.3 ELECTRICAL PARAMETERS**

### **A. Electrical System**

Electrical system comprises a main service panel, control and monitoring (or contactor) cabinet(s), as well as branch circuits feeding all light poles and luminaires, including equipment grounding conductors. Electrical system design shall conform to National Electric Code.

### **B. Disconnect**

There should be provided at each pole a disconnect means located at the minimum height required by code to allow disconnecting of electrical power of the pole. This disconnect should allow for lockout/tagout in addition to overcurrent protection provided at the distribution panel for each individual circuit.

**C. Fusing**

Each luminaire should be individually fused with UL Listed fused equipment rated for use with the system. Fusing shall be located in the remote electrical enclosure located at ground servicing height on the pole.

**D. Lightning Protection**

Each pole should be equipped with lightning protection as established by NFPA 780.

**E. Surge Protection**

Surge protection should be provided at each pole equal to or greater than 40 kA for each line to ground (common mode) as recommended by IEEE C62.41.2 -2002.

**F. Rigid Conduit**

It is recommended that all wiring above grade be internal to the light pole. If necessary to run outside the pole, all conductors should be within a rigid metallic, or liquid-tight flex conduit.

**G. Lockable Electrical Components Enclosures**

Electrical components enclosures that are designed to be opened should be lockable and kept locked except during times of maintenance or servicing. Access should be by means of a key or special tool.

**H. Underground Supply Wiring**

Supply wiring should be buried to depths required by NEC or applicable local code. Copper wire is recommended. Do not share neutrals nor equipment grounding conductors.

**I. Strain Relief**

Wire harness should be supported within the pole as required by electrical code with a strain relief at the top of the pole. For poles taller than 80 feet, a midpoint strain relief should also be supplied.

**J. Voltage Drop**

The voltage drop to the disconnect switch located at the light poles should not exceed 3% of the rated voltage per IESNA RP-6-20.

**K. Underwriter Laboratory Listing**

The lighting and electrical equipment should have a UL Listing to confirm that the equipment has passed the safety tests of Underwriters Laboratory, not only as to the individual components, but also as to the use of the components in the configuration of the lighting system on the field.

**PART 3 – EXECUTION**

**3.1 FIELD QUALITY CONTROL**

**A. Illumination Measurements**

Upon substantial completion of the project and in the presence of the Contractor, Project Engineer, City's Representative, and Manufacturer's Representative, illumination measurements shall be taken and verified. The illumination measurements should be conducted in accordance with IESNA RP-6-20, Annex E.

All points on the field are to be measured as specified on the lighting scan, using a cosine and colorcorrected lightmeter calibrated within the last 12 months. See diagrams below for recording readings.

## **B. Correcting Non-Conformance**

If, in the opinion of the Owner or his appointed Representative, the actual performance levels including footcandles, uniformity ratios, and maximum kilowatt consumptions are not in conformance with the requirements of the performance specifications and submitted information, the Manufacturer shall be liable to any or all of the following:

1. Manufacturer shall at his expense provide and install any necessary additional luminaires to meet the minimum lighting standards. The Manufacturer shall also either replace the existing poles to meet the new wind load (EPA) requirements or verify by certification by a licensed structural engineer that the existing poles will withstand the additional wind load.
2. Manufacturer shall minimize the Owner's additional long term luminaire maintenance and energy consumption costs created by the additional luminaires by reimbursing the Owner the amount of \$1,000.00 (one thousand dollars) for each additional luminaire required.
3. Manufacturer shall remove the entire unacceptable lighting system and install a new lighting system to meet the specifications.

## **II. Desirable Features**

The following practices are recommended for increasing the lighting system performance.

### **4.1 WARRANTY**

When comparing products, the manufacturers' warranty should also be evaluated. The quality of the warranty reflects a manufacturer's confidence in the long-term durability of their equipment. Considerations include the extent of the equipment covered, the duration of the warranty, and whether the warranty provides a guarantee of light levels during the warranty period. From the owner's perspective, the warranty offers the opportunity to reduce costs for equipment repair. Comprehensive warranties covering parts, labor, and shipping costs are available for up to 25 years.

### **4.2 TV QUALITY LIGHTING**

Lighting for televised events involves considerations in addition to spectators and participants. It is recommended that schools wishing to light facilities for television broadcasts use consultants and lighting manufacturers with experience and knowledge in that area.

**NOTE:** For facilities that plan on hosting televised events, the facility should be lit according to the NCAA lighting standards for television broadcasts. To access these standards online, go to <http://www.ncaa.org>, then use the site's search feature to search for "Best Lighting Practices."

### **4.3 DIMMING**

Additional energy savings can be obtained through the use of multi-level lighting. The multi-level lighting will allow the system to operate at the light level that is most appropriate for the activity taking place. For example, a facility may only be used for competitive play a few hours a day with the remainder being used for practice or recreational use. The multi-level lighting would allow for the lights to be operated in the high mode for competition events, while operating on a medium, or a low light level during the remainder of the time, thus conserving energy.

#### **4.4 ENTERTAINMENT PACKAGES/LIGHT SHOWS**

Entertainment packages are often included in control systems and can incorporate predesigned and custom light shows, along with audio to further enhance the player and spectator experience. Some entertainment packages include automated video broadcasting for streaming video for remote spectators.

#### **4.5 AUXILIARY BRACKETS**

Sports lighting manufacturers can provide accommodations for mounting auxiliary equipment such as speakers on sports lighting poles. This ensures poles will be sized to accommodate the weight, dimensions, and wind load (EPA) of the additional equipment. Brackets shall be welded to the pole and fabricated from hot-dip galvanized steel with a covered hand hole access and internal wiring in the pole.

#### **4.6 SERVICING OPTIONS**

Consideration should be given to the method of servicing the top of the pole for lamp replacements and other maintenance concerns that can't be reached with a ladder. The preferred method of servicing should be with a bucket truck or crane. However, when accessibility is restricted due to pole locations, an alternative method should be utilized. Acceptable alternative methods include steps, safety cables, and platforms.

#### **4.7 FIELD PERIMETER LIGHTING**

The parking areas, major areas utilized for passage, and areas immediately bordering the facilities should be lighted to an average of approximately 2 footcandles. Care should be taken to eliminate darkly shadowed areas.

#### **4.8 EMERGENCY LIGHTING FOR SPECTATOR SEATING AREA**

Consideration should be given to providing emergency lighting for spectator seating areas in case of loss of power at indoor and outdoor facilities. Refer to local building codes for specific requirements as they apply to athletic facilities.

**For additional information, contact the IHSAA office at:**

IHSAA  
P.O. Box 10  
Boone, Iowa 50036-0010  
Phone: 515/432-2011  
Fax: 515/432-2961  
[www.iahsaa.org](http://www.iahsaa.org)

## SPORTS LIGHTING RETROFIT LIFE-CYCLE OPERATING COST EVALUATION

*This form will assist you in comparing 25-year life-cycle operating costs of existing HID and new LED lighting. Bid proposals should be evaluated based upon compliance with the specifications, contract price, and the following life-cycle operating cost evaluation.*

### EXISTING HID LIGHTING SYSTEM:

<b>A.</b>	<b>Energy consumption</b> ____ Number of luminaires x ____ kW demand per luminaire x ____ kW rate x ____ annual usage hours x 25 years		
<b>B.</b>	<b>Demand charges, if applicable</b>	+	
<b>C.</b>	<b>Spot relamping and maintenance over 25 years (HID systems)</b> Assume ____ repairs at \$ ____ each if not included	+	
<b>D.</b>	<b>Group relamps during 25 years (HID systems)</b> ____ annual usage hours x 25 years / lamp replacement hours x \$125 lamp & labor x number of luminaires	+	
<b>E.</b>	<b>Extra energy used without control system</b> ____% x Energy Consumption in item A.	+	
<b>F.</b>	<b>Extra labor without control system</b> \$ ____ per hour x ____ hours per on/off cycle x ____ cycles over 25 years	+	
<b>G.</b>	<b>TOTAL 25-Year Life-Cycle Operating Cost</b>	=	

### NEW LED LIGHTING SYSTEM:

<b>A.</b>	<b>Energy consumption</b> ____ Number of luminaires x ____ kW demand per luminaire x ____ kW rate x ____ annual usage hours x 25 years		
<b>B.</b>	<b>Demand charges, if applicable</b>	+	
<b>C.</b>	<b>Spot repairs of LED luminaires</b> Assume ____ repairs at \$ ____ each if not included. Include \$ ____ shipping and \$ ____ installation if not included.	+	
<b>D.</b>	<b>Extra energy used without control system</b> ____% x Energy Consumption in item A.	+	
<b>E.</b>	<b>Extra energy used if no contractor control provided</b> ____% energy consumption	+	
<b>F.</b>	<b>Energy consumption</b> \$ ____ per hour x ____ hours per on/off cycle x ____ cycles over 25 years	+	
<b>G.</b>	<b>TOTAL 25-Year Life-Cycle Operating Cost</b>	=	

**SUBMITTAL INFORMATION**  
**Design Submittal Data Checklist and Certification**

*This form will assist you in comparing proposals from various lighting manufacturers. All items listed below should comply with your project's specification and be submitted according to your pre-bid submittal requirements.*

Included	Tab	Item	Description
	<b>A</b>	Letter/Checklist	Listing of all information being submitted must be included on the table of contents. List the name of the manufacturer's local representative and his/her phone number. Signed submittal checklist to be included.
	<b>B</b>	On Field Lighting Design	Lighting design drawing(s) showing: a. Field Name, date, file number, prepared by b. Outline of field(s) being lighted, as well as pole locations referenced to the center of the field (x & y), Illuminance levels at grid spacing specified c. Pole height, number of luminaires per pole, horizontal and vertical aiming angles, as well as luminaire information including wattage, lumens and optics d. Height of light meter above field surface e. Summary table showing the number and spacing of grid points; average, minimum and maximum illuminance levels in foot candles (fc); uniformity including maximum to minimum ratio, coefficient of variance (CV), coefficient of utilization (CU) uniformity gradient; number of luminaires, total kilowatts, average tilt factor; light loss factor. f. Lighting designs shall provide guaranteed target illuminance levels and shall display the LM-80 lumen maintenance data used to calculate illuminance.
	<b>C</b>	Off Field Lighting Design	Lighting design drawings showing spill light levels in footcandles as specified and candela at 150 feet or at property line.
	<b>D</b>	Photometric Report	Provide photometric report for a typical luminaire used showing candela tabulations as defined by IESNA Publication, LM-79-08. Photometric data shall be certified by laboratory with current National Voluntary Laboratory Accreditation Program or an independent testing facility with over 5 years experience.
	<b>E</b>	Life Cycle Cost calculation	Document life cycle cost calculations as defined on the Life Cycle Operating Cost Evaluation. Identify energy costs for operating the luminaires, maintenance cost for the system including spot maintenance and shipping costs. All costs should be based on 25 years.
	<b>F</b>	Luminaire Aiming Summary	Document showing each luminaire's aiming angle and the poles on which the luminaires are mounted. Each aiming points shall identify the type of luminaire.
	<b>G</b>	Structural Calculations	Pole structural calculations and foundation design showing foundation shape, depth backfill requirements, rebar, and anchor bolts (if required). Pole base reaction forces shall be shown on the foundation drawing along with soil bearing pressures. Design must be stamped by a structural engineer in the state of Iowa.
	<b>H</b>	Control and Monitoring	Manufacturer shall provide written definition and schematics for automated control system to include monitoring. They will also provide examples of system reporting and access for numbers for personal contact to operate the system.
	<b>I</b>	Electrical distribution plans	If bidding an alternate system, manufacturer must include a revised electrical distribution plan including changes to service entrance, panels and wire sizing, signed by a licensed Electrical Engineer in the state of Iowa.
	<b>J</b>	Performance Guarantee	Provide performance guarantee including a written commitment to undertake all corrections required to meet the performance requirements noted in these specifications at no expense to the owner. Light levels must be guaranteed per the number of years specified.
	<b>K</b>	Warranty	Provide written warranty information including all terms and conditions.
	<b>L</b>	Project References	Manufacturer to provide a list of a minimum of 10 project references of similar products completed within the past three years within in the state.
	<b>M</b>	Product Information	Complete set of product brochures for all components, including a complete parts list and UL Listings.
	<b>N</b>	Non-Compliance	Manufacturer shall list all items that do not comply with the specifications.
	<b>O</b>	Compliance	Manufacturer shall sign off that all requirements of the specifications have been met at that the manufacturer will be responsible for any future costs incurred to bring their equipment into compliance for all items not meeting specifications and not listed in item N – Non-Compliance.

**Manufacturer:**  
**Contact Name:**

**Signature:** \_\_\_\_\_  
**Date:** \_\_\_\_\_/\_\_\_\_\_/\_\_\_\_\_

# Appendix

## Typical Facility Information

Area of Lighting	Playing Dimensions (feet)	Grid Spacing (feet)	Minimum # of Grids
Baseball, Infield	90' x 90'	30' x 30'	25
Baseball, Outfield	Dimensions Vary	30' x 30'	Varies
Softball, Infield	60' x 60'	20' x 20'	25
Softball, Outfield	Dimensions Vary	20' x 20'	Varies
Football	360' x 160'	30' x 30'	72
Soccer	360' x 180'	30' x 30'	72
Lacrosse	330' x 180'	30' x 30'	66
Field Hockey	300' x 180'	30' x 30'	60
Rugby	330' x 180'	30' x 30'	66
Tennis	78' x 36'	20' x 20'	15
Gymnasiums	94' x 50'	10' x 10'	50
Track and Field	Dimensions Vary	30' x 30'	Varies

**Light  
Level**

## Grid Point Layouts

### Baseball

300' radius field shown

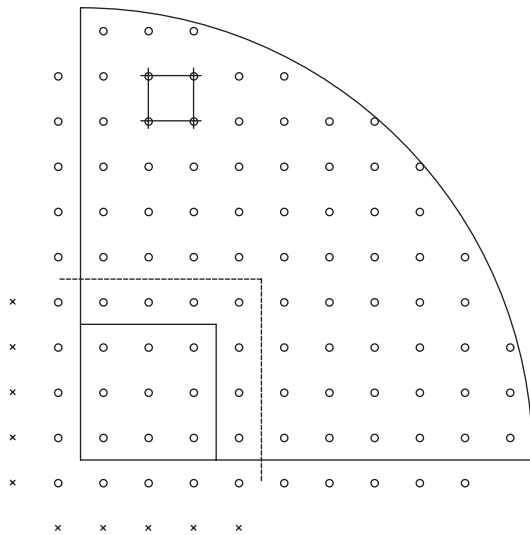

### Softball

200' radius field shown

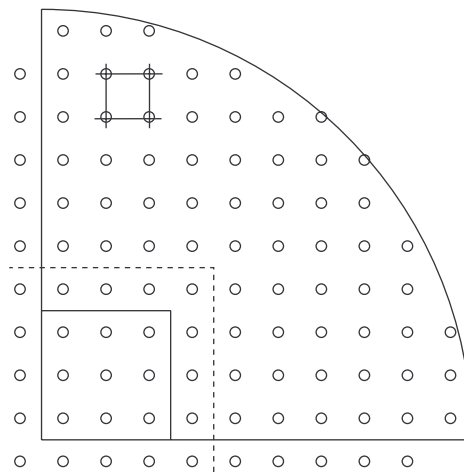



## Football

360' x 160' field shown

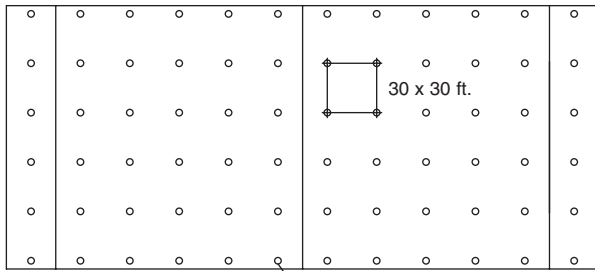

Grid Points

## Gymnasium

94' x 50' court shown

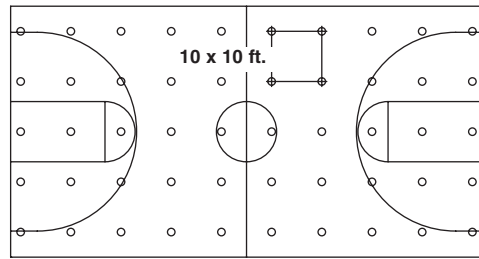

## Soccer

360' x 180' field shown

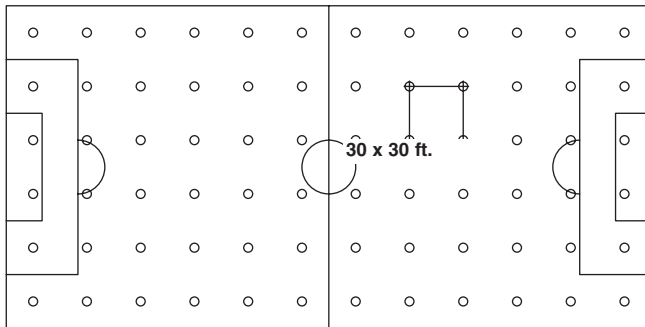

## Tennis

78' x 36' court shown

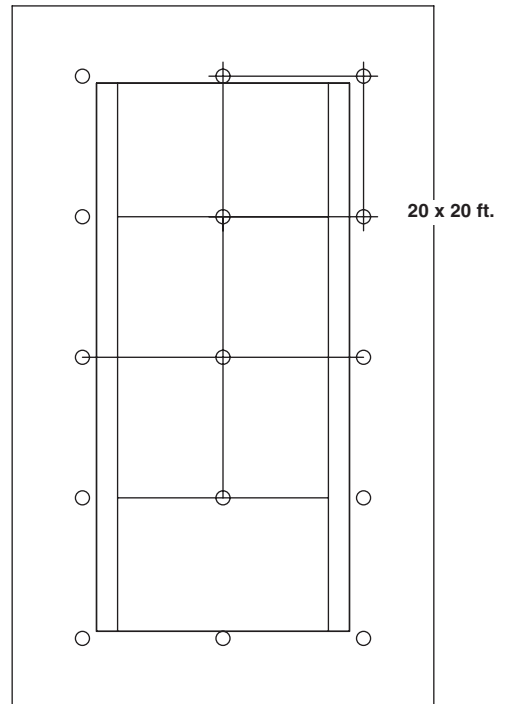

## Track

400 meter, 8 lane track shown

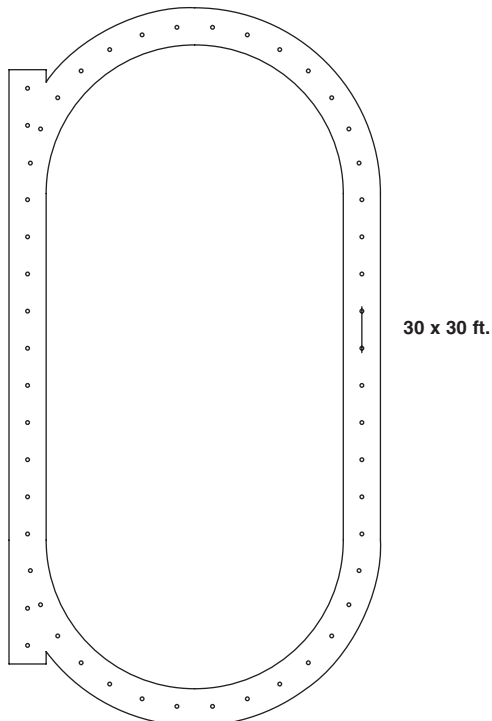

## Lacrosse

330' x 180' field shown

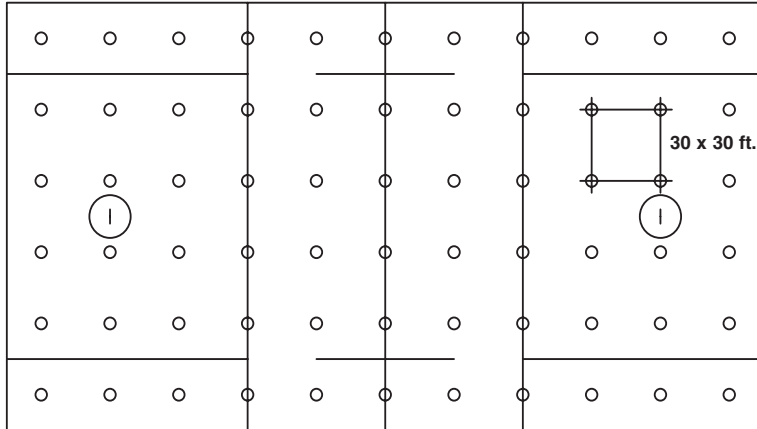

## Field Hockey

300' x 180' field shown

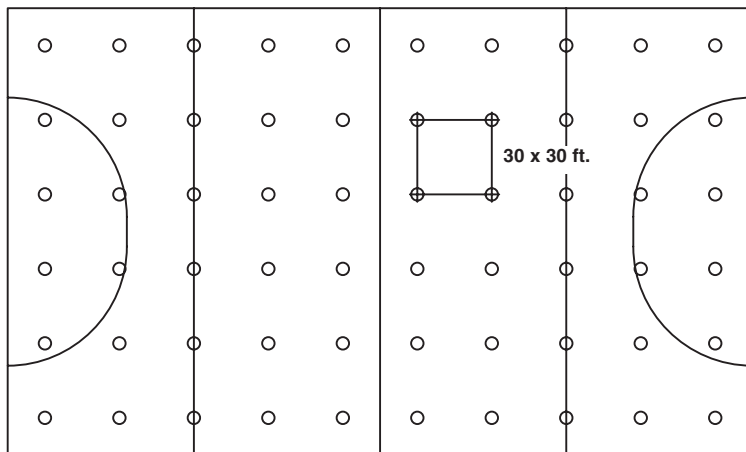

## Rugby

330' x 180' field shown

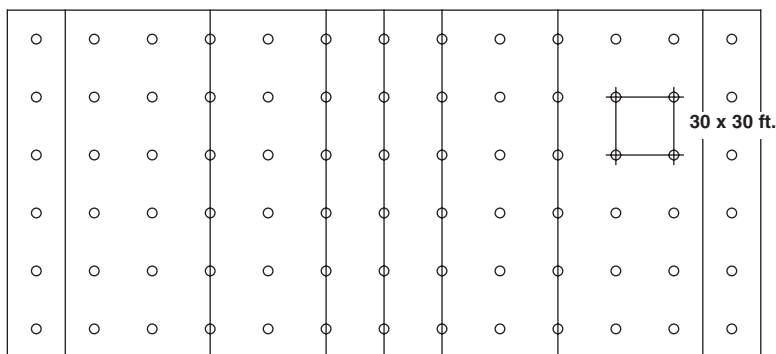

## Pole Location Diagrams

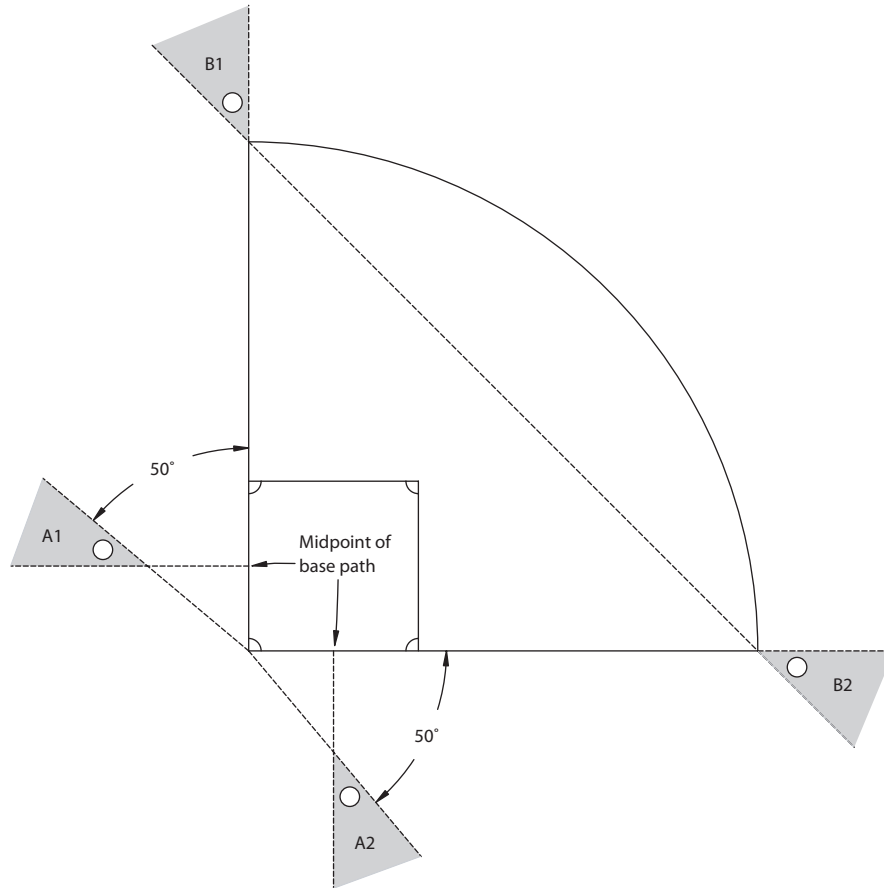

### 4-Pole Softball Field

1. Poles are shown in optimal locations. Other permissible pole locations are indicated by the shaded areas.
2. For fields with a radius of 250 feet or greater, a 6-pole design is recommended.
3. Line drawn through the two "A" pole locations should be behind home plate to ensure lighting the portion of the ball the batter sees as it crosses home plate.

Note:

IES standards have not addressed issues for 4-pole design on softball fields. Design criteria are based upon actual practices used on 250' and smaller fields and standards adopted by Little League Baseball and ASA Softball based upon testing done on their facilities.

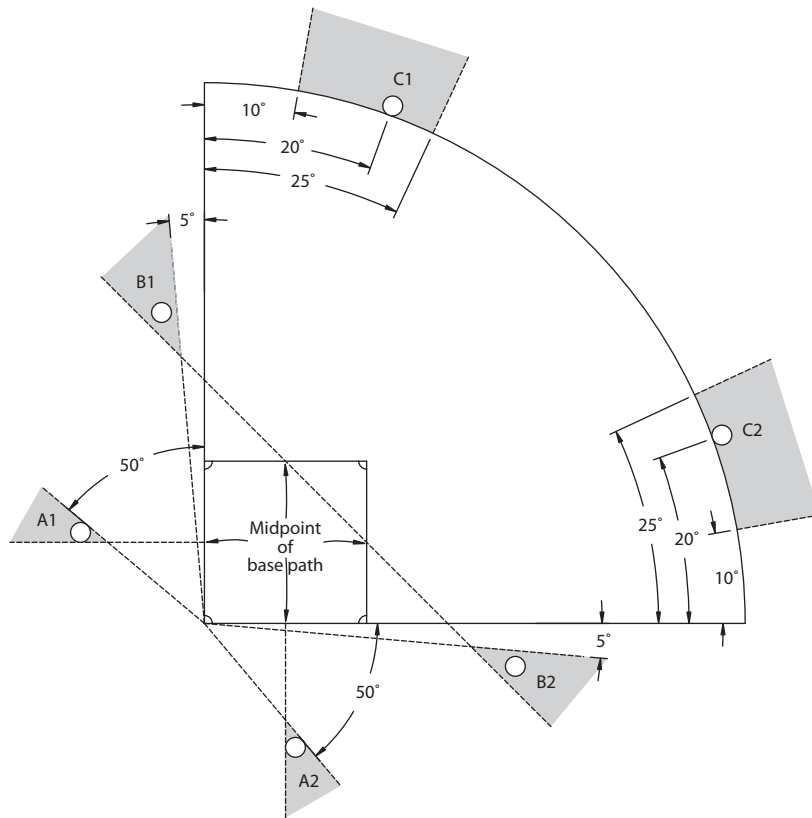

### 5\* or 6-Pole Baseball/Softball Field

1. Poles are shown in optimal locations. Other permissible pole locations are indicated by the shaded areas.
2. For fields with a radius of 320 feet or greater, an 8-pole design is recommended.
3. Line drawn through the two "A" pole locations should be behind home plate to ensure lighting the portion of the ball the batter sees as it crosses home plate.
4. Consideration should be given to locating "B" poles further toward the outfield locations. This positioning towards the outfield foul pole allows the ball to be lighted in a more constant perpendicular illuminance as it travels from the infield to the outfield.

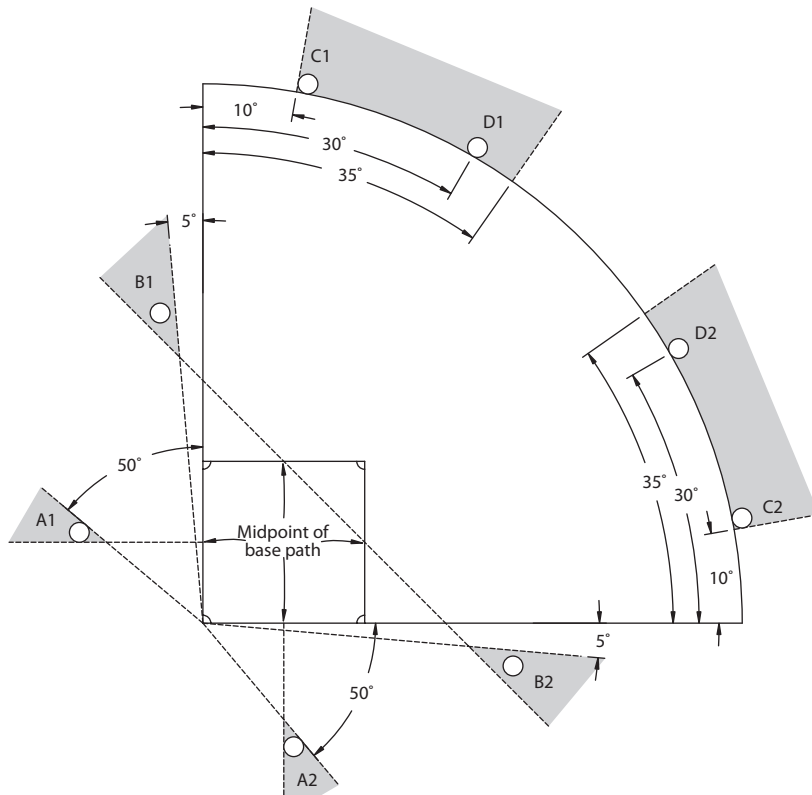

## 7\* or 8-Pole Baseball/Softball Field

1. Shaded areas indicate recommended pole location.
2. Line drawn through each "A" pole location must be behind home plate to ensure lighting the portion of the ball the batter sees as it crosses home plate.
3. Consideration should be given to locating "B" poles further towards outfield locations. This positioning towards the outfield foul pole allows the ball to be lit in a more constant perpendicular illuminance as it travels from the infield to the outfield.
4. "B" poles may be located 10 feet closer to the infield as long as they maintain a position outside the 10 degree arc. The shaded area is preferable.

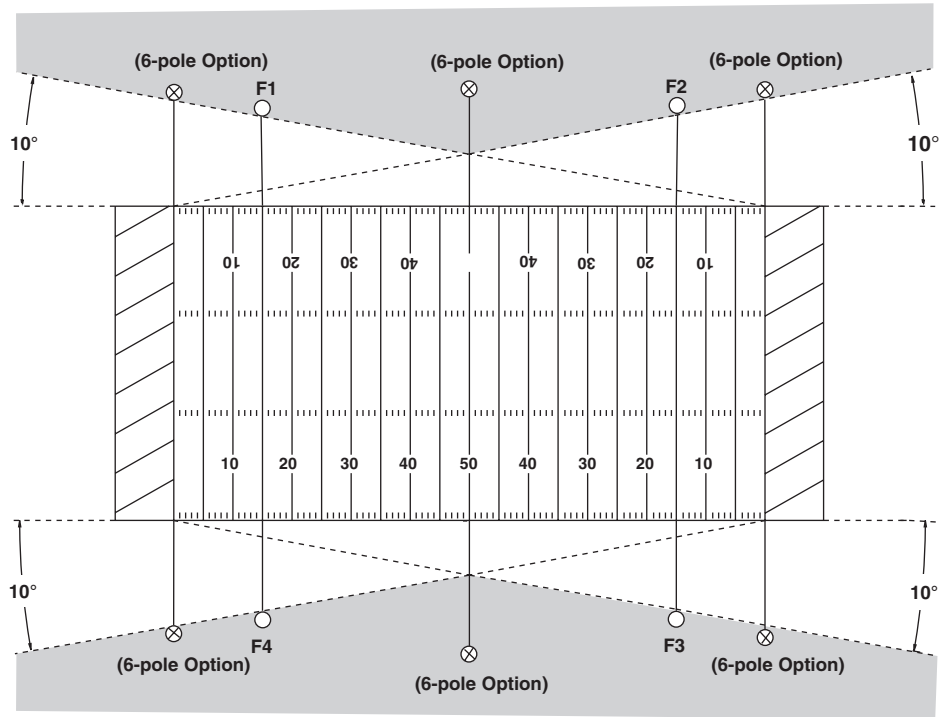

## Football Field

1. Shaded areas indicate recommended pole location. All poles should be at least 45 feet from sideline.
2. On a 4-pole design, poles should be located between the 20-yard line and the goal line.
3. For the 6-pole option, setback of middle poles will depend on the presence of bleachers.
4. For TV consideration on a 6-pole design, outside poles should be located toward the end zone line. Optimum placement for TV is 10-15 feet off the end zone line for an end zone camera.
5. For practice facilities, the lighting should be approximately 20 footcandles with 2 poles on each side of the field with aiming angles of 25 degrees. Poles should be in position so not to pose a potential injury. Electrical and structural guidelines should be strictly adhered to as outlined in these standards.

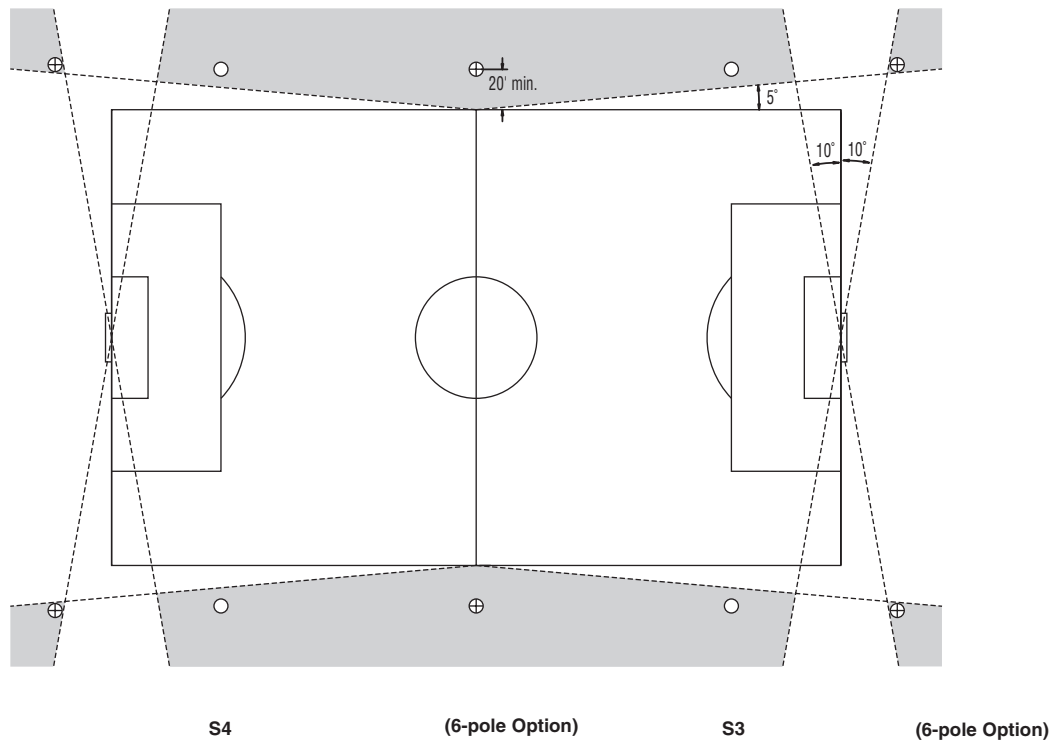

## Soccer Field

1. Poles are shown in optimal locations. Other permissible pole locations are indicated by the shaded areas. All poles should be at least 20 feet from the sideline.
2. On a 4-pole design, the optimum pole locations are (.35 x field length) from center of field.
3. In general, football lighting standards apply to soccer with the following considerations:
  - a. A corner kick is a specific visual task and general consideration should be given to facility design specifically for soccer.
  - b. The corner grid point shall be lit to no less than 90% of the average light level.
4. For combination football and soccer facilities, soccer should take precedence.
5. Vertical aiming angles should be 21 degrees minimum. The angles are measured from below a horizontal plane at luminaire height.

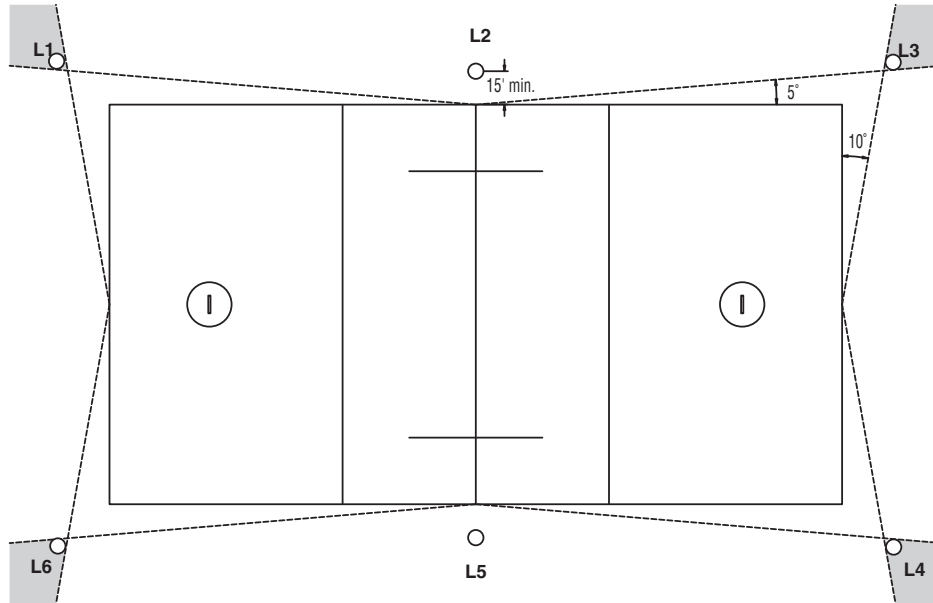

## Lacrosse Field

1. Poles are shown in optimal locations. Other permissible pole locations are indicated by the shaded areas. All poles should be at least 15 feet from the sideline.
2. Vertical aiming angle should be 21 degrees minimum. The angles are measured from below a horizontal plane at luminaire height.
3. A 4-pole design utilizing corner location is permissible providing minimum aiming angles can be achieved.



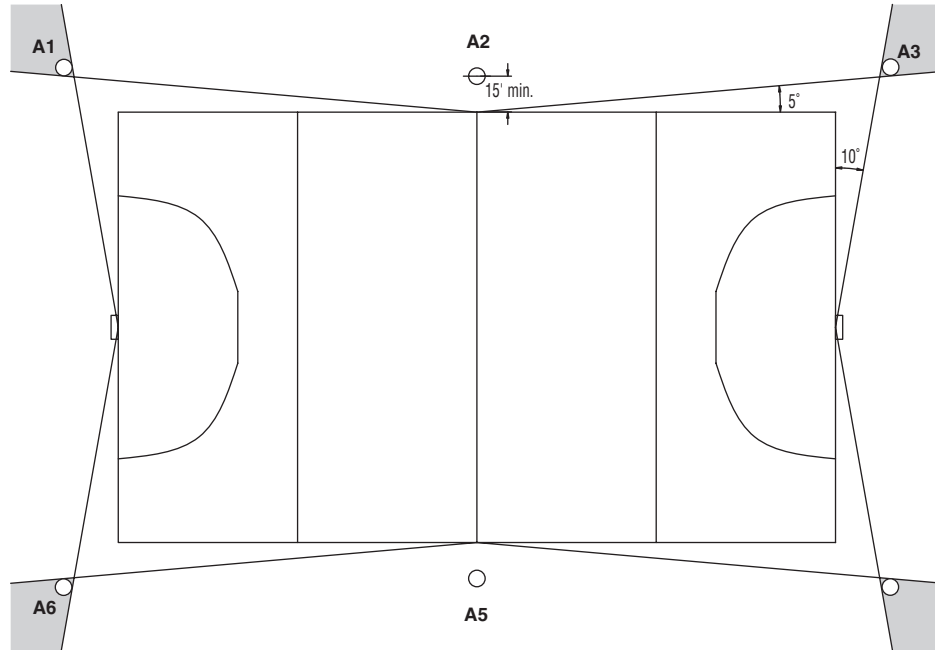

## Field Hockey Field

1. Poles are shown in optimal locations. Other permissible pole locations are indicated by the shaded areas. All poles should be at least 15 feet from the sideline.
2. Vertical aiming angle should be 21 degrees minimum. The angles are measured from below a horizontal plane at luminaire height.
3. A 4-pole design utilizing corner location is permissible providing minimum aiming angles can be achieved.

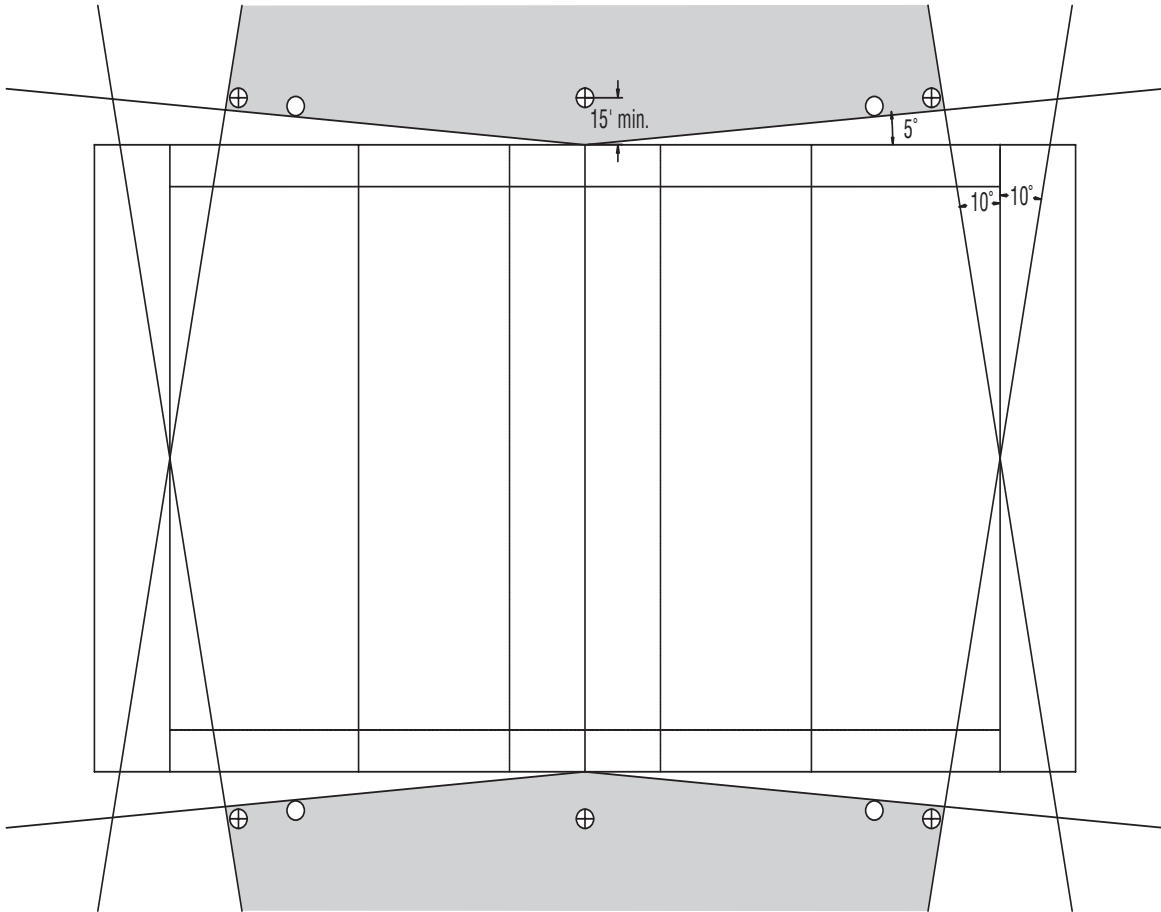

## Rugby Field

1. Poles are shown in optimal locations. Other permissible pole locations are indicated by the shaded areas. All poles should be at least 15 feet from the sideline.
2. On a 4-pole design, the optimum pole locations are (.35 x field length) from center of field.
3. Poles should be positioned so as not to pose a potential injury hazard.
4. Vertical aiming angle should be 21 degrees minimum. The angles are measured from below a horizontal plane at luminaire height.

## 12 Luminaire Design

Designed for lighting in gymnasiums with no special provision for spectators such as smaller high schools or training facilities.

- 54 footcandles maintained

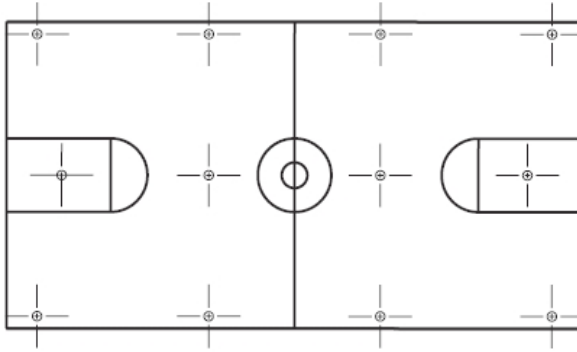

## 20 Luminaire Design

Ideal for college, semi-professional, or large high schools with facilities for spectators of 5000 or less. Suitable for facilities where lighted surfaces are 50' x 94' with 22' mounting heights.

- 80 footcandles maintained

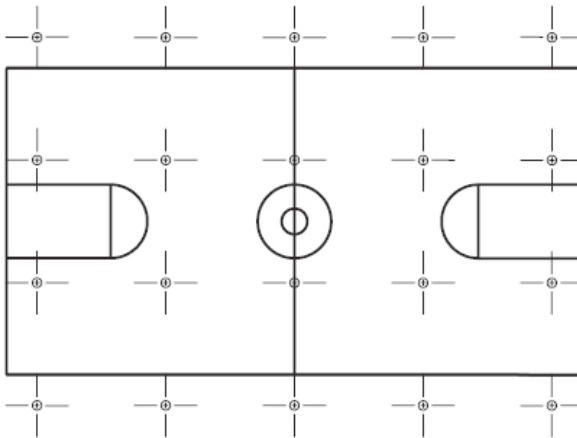

## Gymnasium

1. For new facilities or upgrades, it is recommended to consult a lighting professional for optimal fixture placement.
2. Optimal fixture placement and mounting heights will impact playability and minimize glare and skip glare.
3. As a general rule, due to mounting heights, lower wattage fixtures are used, commonly 1000 watt.

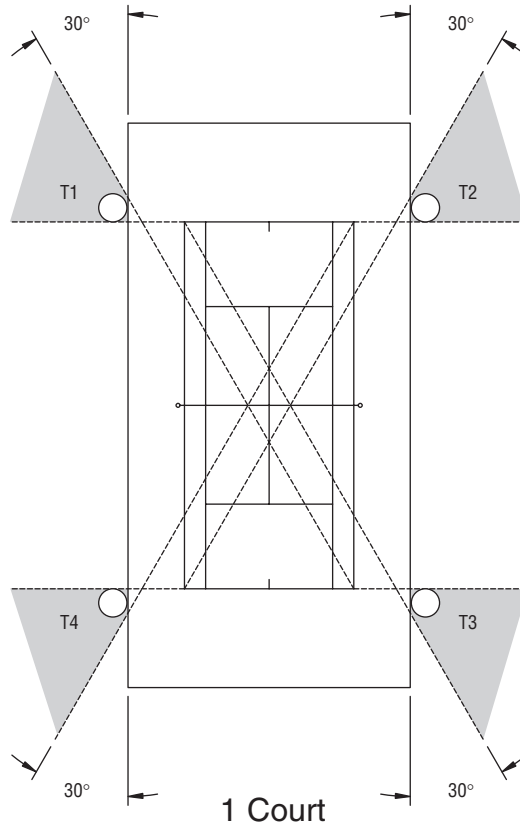

## Tennis Courts

1. Poles are shown in optimal locations. Other permissible pole locations are indicated by the shaded areas.
2. It is not generally recommended to use a 6-pole layout with poles located at net lines. This position may be directly in the server's sight line with toss when the ball is served.
3. Vertical aiming angles should be 25 degrees minimum. The angles are measured from below a horizontal plane at luminaire height.

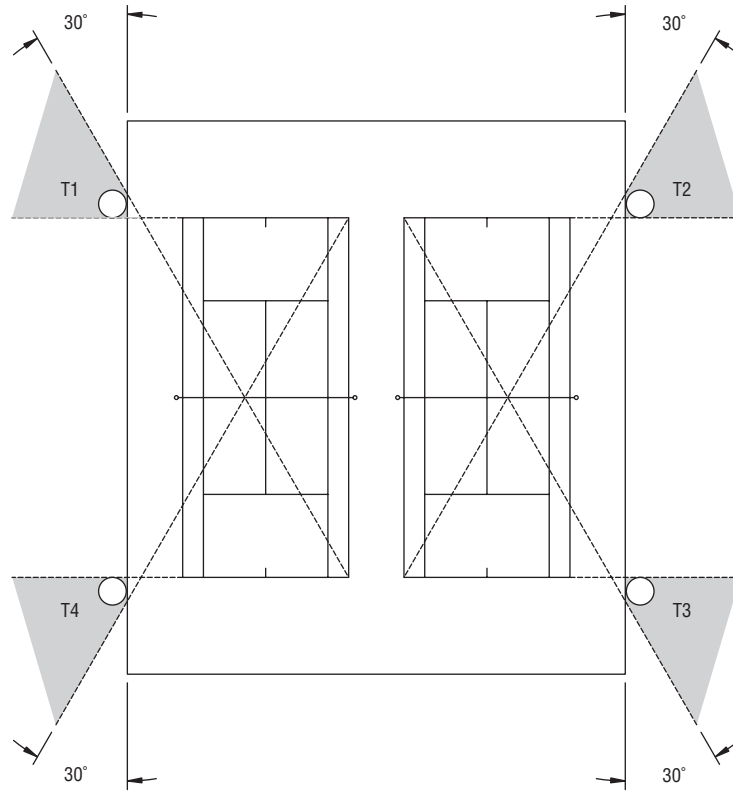

2 Courts

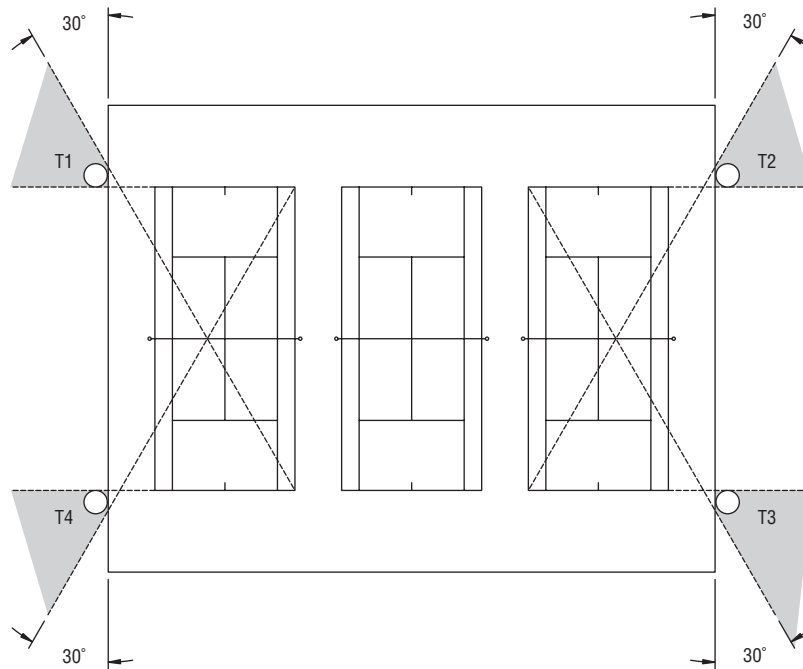

3 Courts

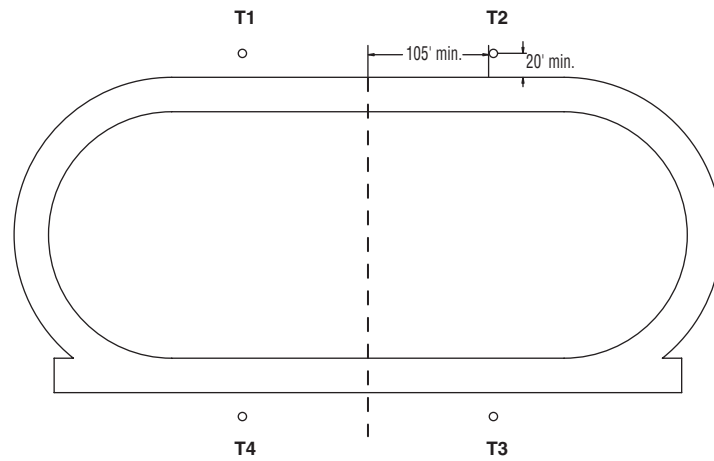

4-Pole Track

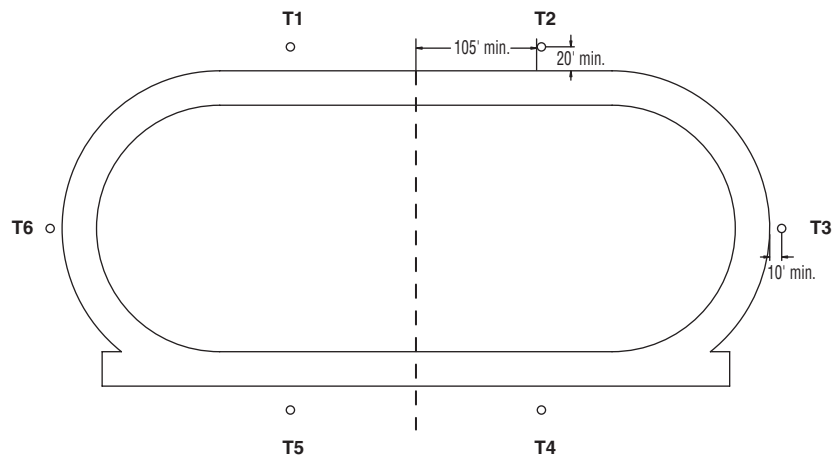

6-Pole Track

### 400 Meter, 8 Lane Track

1. These pole locations are for typical stand-alone tracks.
2. For tracks built in conjunction with a football or soccer field, use the standard pole locations on the football design (page 16) or soccer design (page 16).

# ANNUAL SYSTEM OPERATION & MAINTENANCE CHECKLIST

School Name \_\_\_\_\_ Field Name \_\_\_\_\_  
 Date of Inspection \_\_\_\_\_ Voltage/Phase \_\_\_\_\_ Date Installed \_\_\_\_\_  
 Type of Pole \_\_\_\_\_ Type/# of Luminaires \_\_\_\_\_  
 Inspected By \_\_\_\_\_ Title: \_\_\_\_\_ Contact Number \_\_\_\_\_

		OK	Needs Repair	N/A	Notes
WARNING! Turn off electricity at power source and at safety disconnect on poles	<b>Lighting Performance Testing</b>				
	Check with the AD and Staff to see if there are any concerns regarding field (pole, electrical or lighting)				
	Average maintained footcandles meet guidelines				
	Uniformities meet guidelines				
	<b>Service Entrance, Poles, and Distribution Boxes</b>				
	Warning Stickers, wiring diagrams, circuit labels should be posted and legible				
	Snap all breakers on and off several times to ensure firm contact. Utilizing breakers for on/off control is not recommended due to reducing the effectiveness of the devices for overcurrent protection. Also, risk of arc flash is increased as breakers age and appropriate precautions should be taken.* See NEC 110.16-A Arc Flash				
	Check fuses for continuity*				
	Insulation around wiring should show no signs of deterioration*				
	Wiring should show no heat discoloration*				
	Signs of wear should be replaced on taped connections*				
	Bare wires and exposed connections should be wrapped with insulated covering*				
	Are the panels appropriately locked or access minimized from the public				
	Check all grounding connections at service entrance and at poles. The grounding systems are required to comply with NFPA 70.* 1. Is a ground rod present? 2. Are the bolted connections in good condition? 3. Are the grounding components from acceptable materials and are they sized properly? 4. Is the resistance level satisfactory? This can be verified by measuring resistance to ground. Which for a single rod it should be 25 ohms or less. If it's higher, then a second ground rod shall be added. There is no requirement for minimum resistance value, if two grounds are installed.				
	<b>Pole Structures</b>				
	Wood poles checked for leaning and resulting misalignment of luminaires				
	Wood poles checked for twisting and resulting misalignment of luminaires				
	Wood poles checked for decay. Just below ground level, woodpecker holes etc.				
	Steel anchor bolt poles checked for signs of corrosion				
	Steel anchor bolt poles checked for proper drainage in grout at base				
	Direct burial steel poles checked for proper mastic covering above/below grade at base to ensure no corrosion or pitting of the galvanized protection is evident				
	Direct burial steel poles checked for water/moisture inside pole and corrosion around base of pole				
	Direct burial steel poles checked for proper mastic covering inside the pole				
	Pull on conduits in hand holes to check for looseness*				
	Check for all pole electrical access covers in place				
	Check for all external cable conduit to be in good shape, not cracked or missing*				
	Check for other visible signs of deterioration? Specify				
	Check any pole climbing equipment for proper attachment, alignment and decay or corrosion				
	Check to make sure trees are not encroaching on the pole structures or overhead wires				
	<b>Luminaires</b>				
	Check for signs of smoky film on lenses, or water damage to luminaires				
	Check for broken or missing lenses, replace as needed				
	Check for luminaires not operating. Troubleshoot and repair (fuse, lamp, ballast or capacitor for HID)*				
Visually inspect ballast/drivers for signs of deterioration					
Do any of the luminaires need realignment (visual and light level testing)					
Insulation covering on wiring should show no signs of wear or cracking*					
Ground wire connections must be secure*					
Check around ballasts for signs of blackening. (metal halide)					
Check that capacitors aren't bulging. (metal halide)					
Check aiming alignment of all luminaires.					
On wooden poles, see if crossarms are still aligned with the field and horizontal.					

\*These tests and/or repairs require the services of a qualified electrician.

# Lighting Performance Testing

To verify that your field meets the THSAA recommended standards, complete the performance testing information below. The inspection must be done using a light meter calibrated within the last 12 months. The light meter should be held horizontally 36 inches above the middle point of each square in the grid.

## Baseball/Softball

To obtain average footcandle value:

Record light readings within each square.

Infield = Total of infield readings  $\div$  25

Outfield = Total of outfield readings  $\div$  number of readings.

To obtain uniformity ratio for infield or outfield:

Divide highest (maximum) light level reading by the lowest (minimum) light level reading:

Maximum reading \_\_\_\_\_  $\div$  Minimum reading \_\_\_\_\_ = \_\_\_\_\_ Uniformity ratio

For example:

61 footcandles  $\div$  31 footcandles = 2.1

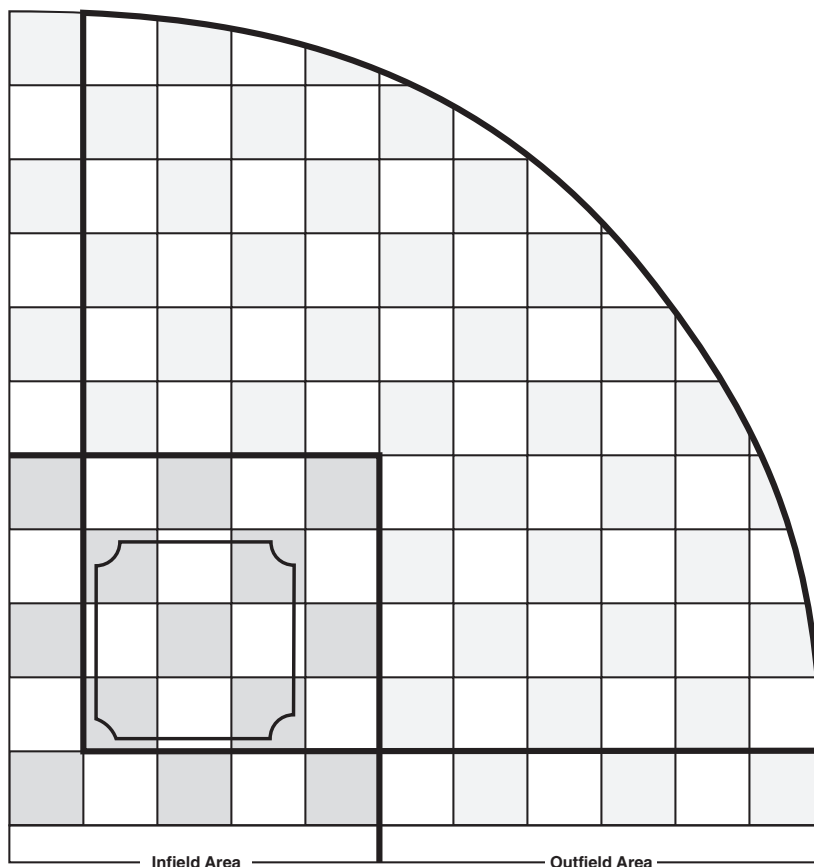
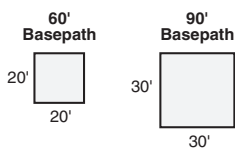



## Football

### To obtain average footcandle value:

Record light readings within each square.

Total all readings, divide by total number of readings taken.

### To obtain uniformity ratio:

Divide highest (maximum) light level reading by the lowest (minimum) light level reading:

Maximum reading \_\_\_\_\_ ÷ Minimum reading \_\_\_\_\_ = \_\_\_\_\_ Uniformity ratio

30' x 30' grid

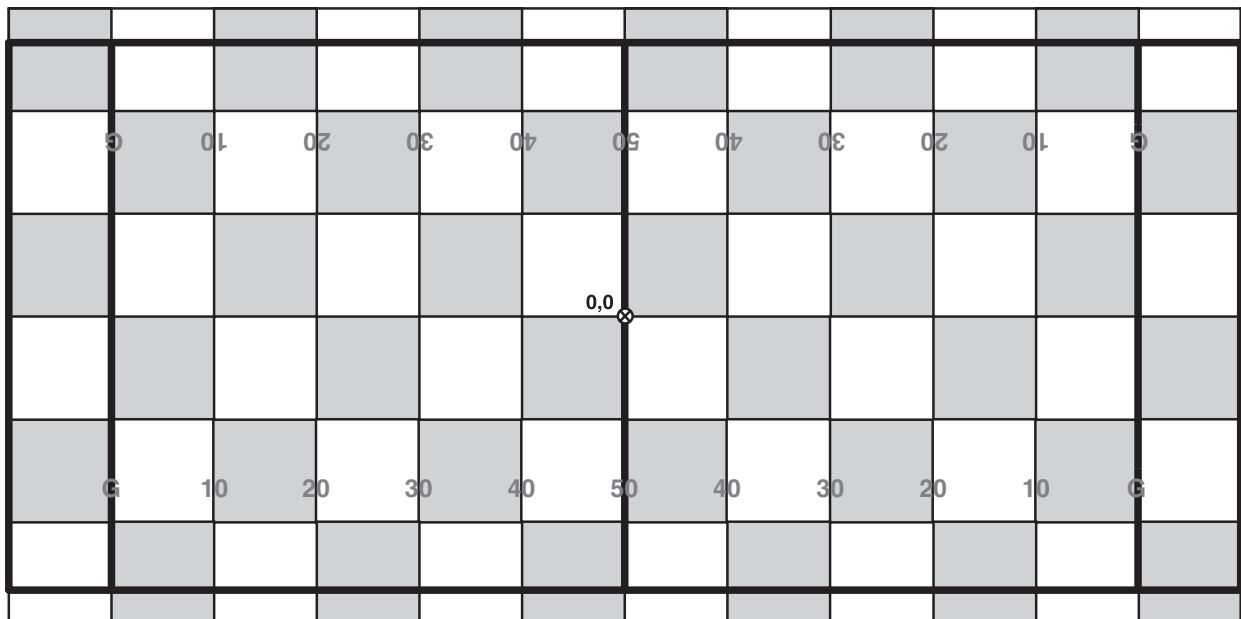

## Soccer

### To obtain average footcandle value:

Record light readings within each square.

Total all readings, divide by total number of readings taken.

### To obtain uniformity ratio:

Divide highest (maximum) light level reading by the lowest (minimum) light level reading:

Maximum reading \_\_\_\_\_ ÷ Minimum reading \_\_\_\_\_ = \_\_\_\_\_ Uniformity ratio

30' x 30' grid

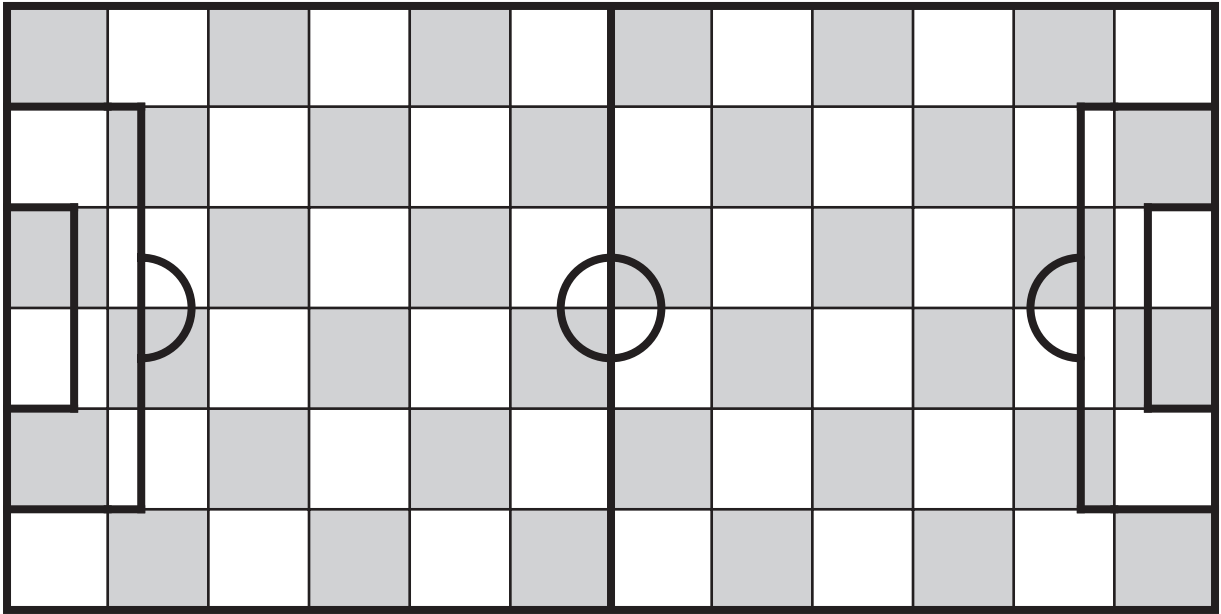

## Lacrosse

### To obtain average footcandle value:

Record light readings within each square.

Total all readings, divide by total number of readings taken.

### To obtain uniformity ratio:

Divide highest (maximum) light level reading by the lowest (minimum) light level reading:

Maximum reading \_\_\_\_\_ ÷ Minimum reading \_\_\_\_\_ = \_\_\_\_\_ Uniformity ratio

30' x 30' grid

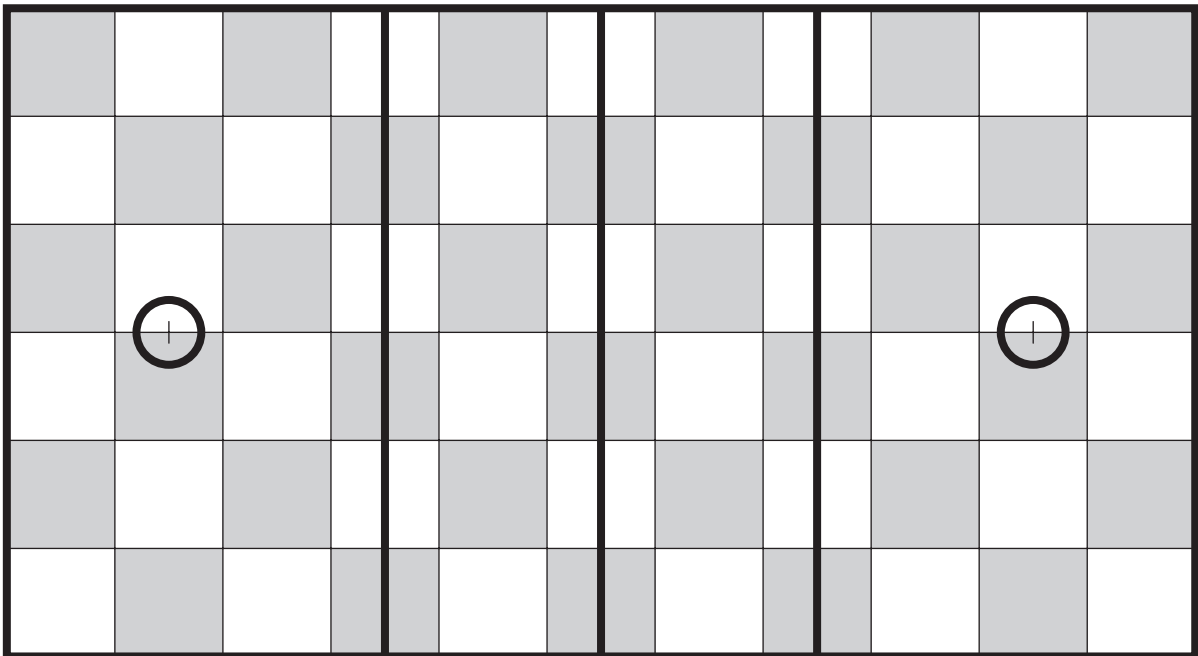

## Field Hockey

To obtain average footcandle value:

Record light readings within each square.

Total all readings, divide by total number of readings taken.

To obtain uniformity ratio:

Divide highest (maximum) light level reading by the lowest (minimum) light level reading:

Maximum reading \_\_\_\_\_ ÷ Minimum reading \_\_\_\_\_ = \_\_\_\_\_ Uniformity ratio

30' x 30' grid

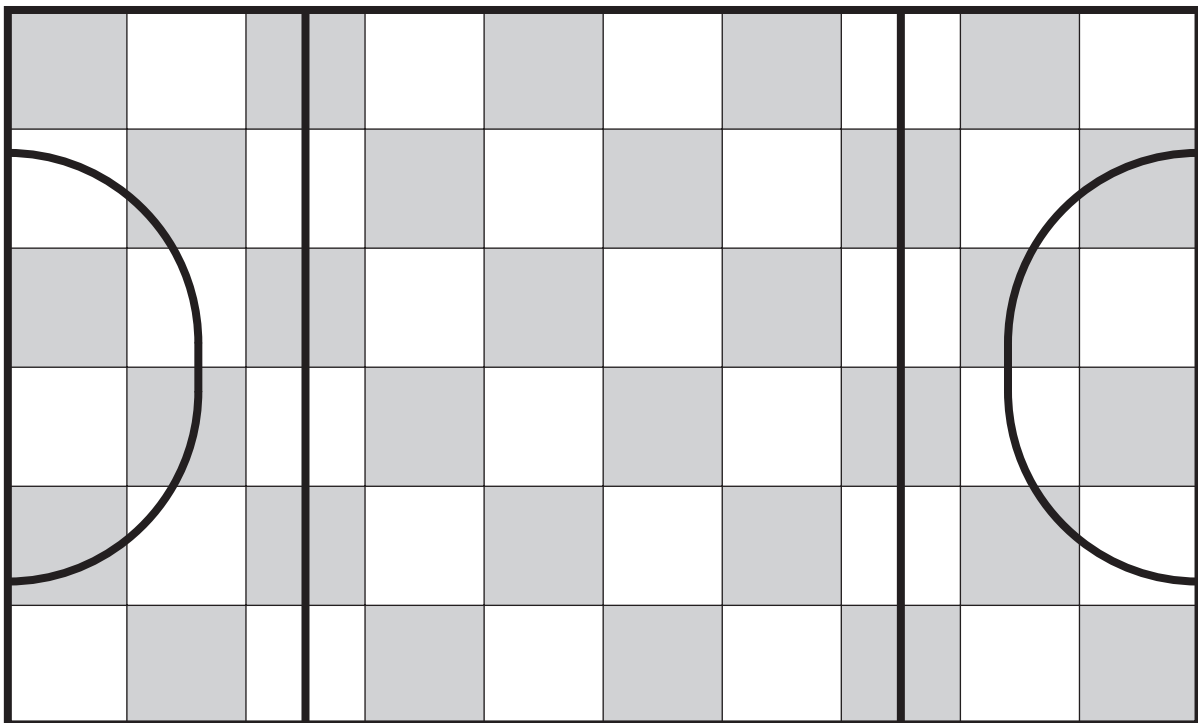

**Rugby**

**To obtain average footcandle value:**

Record light readings within each square.

Total all readings, divide by total number of readings taken.

**To obtain uniformity ratio:**

Divide highest (maximum) light level reading by the lowest (minimum) light level reading:

Maximum reading \_\_\_\_\_ ÷ Minimum reading \_\_\_\_\_ = \_\_\_\_\_ Uniformity ratio

30' x 30' grid

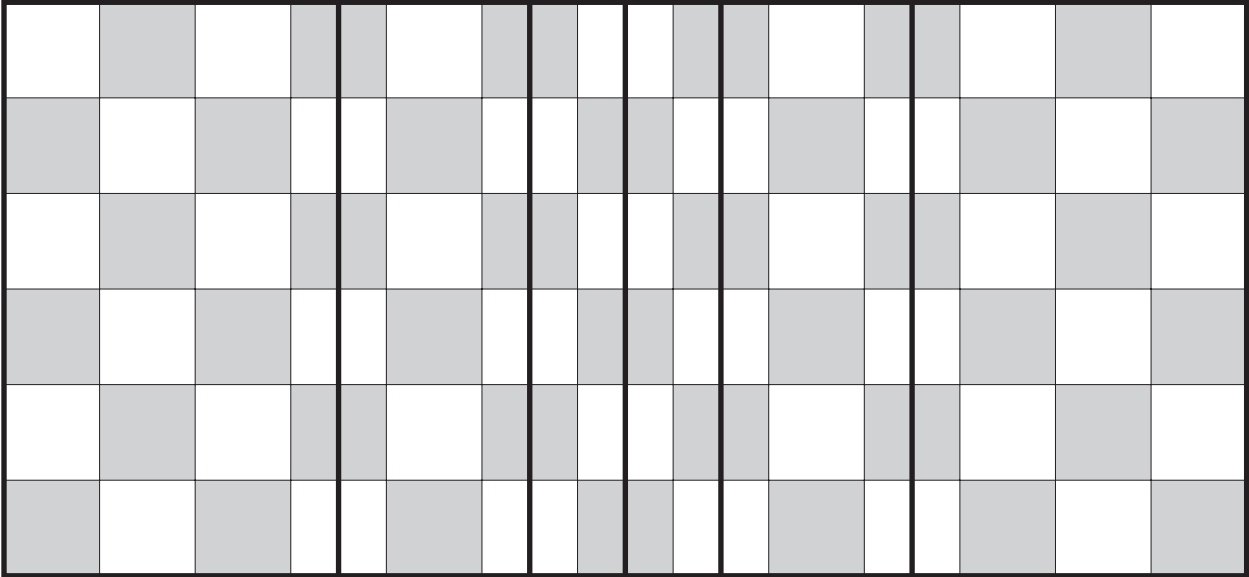

## Gymnasium

To obtain average footcandle value:

Record light readings within each square.

Total all readings, divide by total number of readings taken.

To obtain uniformity ratio:

Divide highest (maximum) light level reading by the lowest (minimum) light level reading:

Maximum reading \_\_\_\_\_ ÷ Minimum reading \_\_\_\_\_ = \_\_\_\_\_ Uniformity ratio

10' x 10' grid

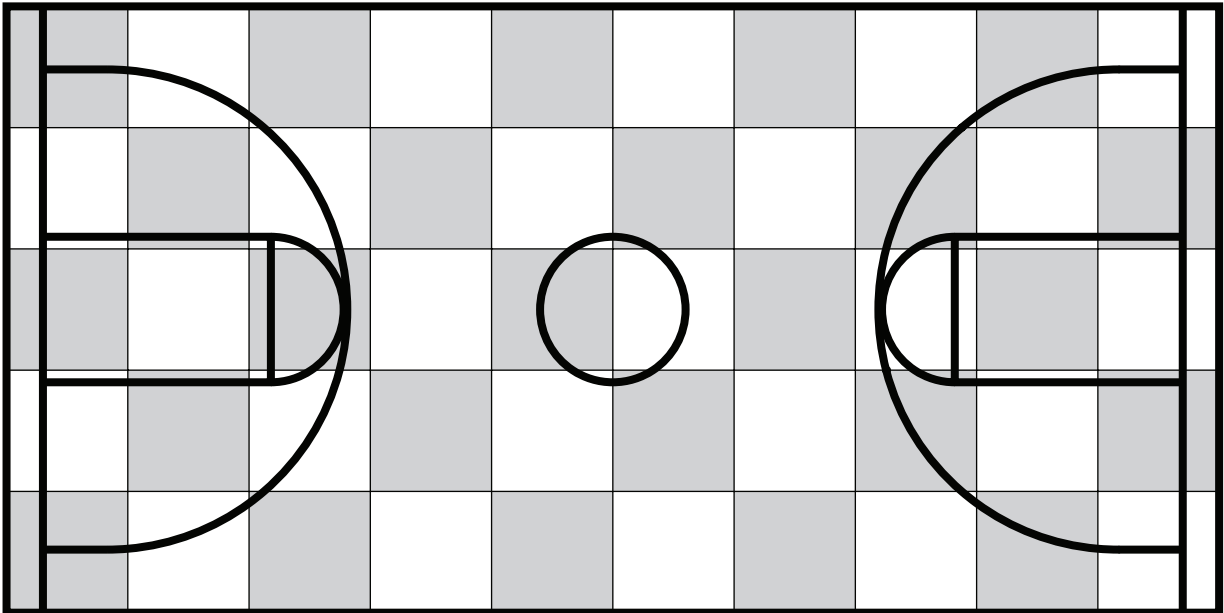

# Tennis

## To obtain average footcandle value:

Record light readings within each square.

Total all readings, divide by total number of readings taken.

## To obtain uniformity ratio:

Divide highest (maximum) light level reading by the lowest (minimum) light level reading:

$$\text{Maximum reading} \div \text{Minimum reading} = \text{Uniformity ratio}$$

20' x 20' grid

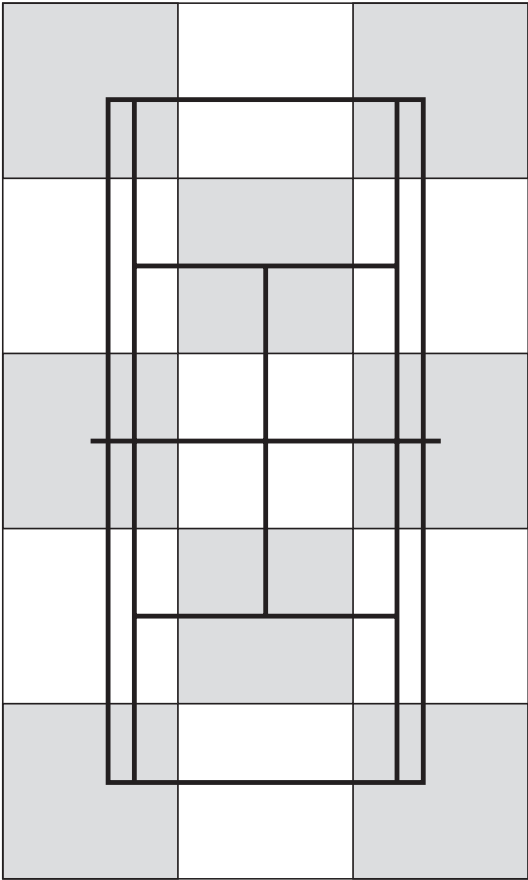

## Track

### To obtain average footcandle value:

Record light readings within each square.

Total all readings, divide by total number of readings taken.

### To obtain uniformity ratio:

Divide highest (maximum) light level reading by the lowest (minimum) light level reading:

Maximum reading \_\_\_\_\_ ÷ Minimum reading \_\_\_\_\_ = \_\_\_\_\_ Uniformity ratio

30' x 30' grid

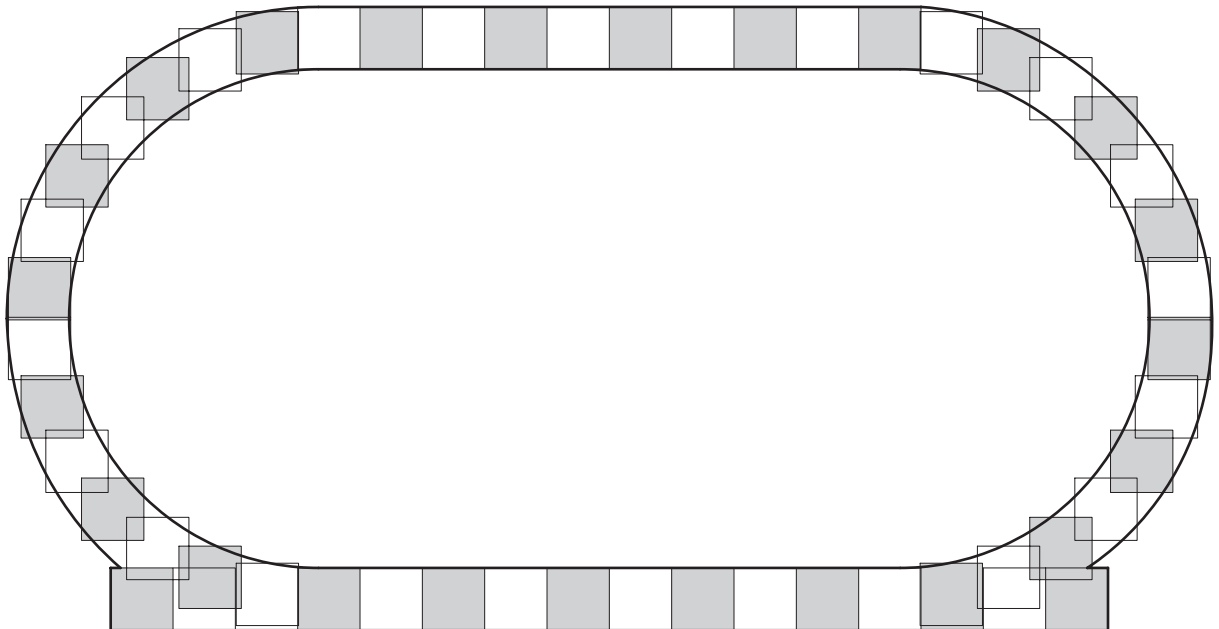



## GLOSSARY

**Aiming Angles (vertical)** The degrees below horizontal that light luminaires are aimed at the field. Angles are measured from a horizontal plane at luminaire height. Critical in safe, playable lighting design.

**Candela** A unit that represents the intensity of light, the eye experiences, from a specific viewing angle of a source.

**Coefficient of Variation** The ratio of the standard deviation for all of the footcandle values to the average. A maximum ratio is specified.

**Color Rendering Index** The ability of a light source to reproduce colors accurately, compared to the same colors under daylight conditions.

**Color Temperature** The color appearance of a light source, measured in Kelvin.

**Controller** A device that regulates the output of an LED driver to control LED luminaire lumen output.

**Driver** A power source that delivers the proper operating current to LED luminaires.

**Footcandle** The measurement of light on a surface. One footcandle equals one lumen spread over one square foot.

**Glare** Light that interferes with the ability to see. Luminaire design, proper aiming angles, and pole locations are key to limiting glare for participants and spectators.

**IESNA** Illuminating Engineering Society of North America. An organization that develops recommendations for sports lighting.

**Lumen** A quantity measurement of light, used mostly in measuring the amount of light an LED creates.

**Luminaire NEMA Type** A classification of luminaires. For example, a Nema 2 luminaire gathers light in a narrow, focused beam, allowing it to be projected a long distance. A Nema 5 projects light a relatively short distance in a very wide beam. Most lighting designs use various combinations of Nema types to get the desired results.

**NEC** National Electric Code. A national safety code for electrical systems that is the basis for most local codes.

**NFPA** National Fire Protection Association. An organization that establishes and publishes various codes such as the Lightning Protection Code and the National Electric Code.

**Overturning Moment** The amount of force applied to a lighting structure, mostly from wind. Pole foundations must be designed to withstand this force.

**Remote Electrical Components Enclosure** A weatherproof enclosure that allows the electrical gear to be moved from the top of lighting structures to a lower point where it can be serviced from a step ladder.

**Spill Light** Wasted light that falls off the field or is projected into the sky. Systems that can re-direct spill light back onto the field save dollars and keep neighbors content.

**Target Light Levels** The lowest average amount of light for which a lighting system should operate over its extended life to ensure performance requirements.

**Underwriters Laboratories** Independent, non-profit, product safety testing and certification organization. Visit [www.ul.org](http://www.ul.org) for additional information.

**Uniformity** The smoothness of light on the field. Also called uniformity ratio. A design criteria to assure that light is distributed evenly across the entire field. A max/min ratio of 2:1 means that the brightest point is no more than double any other point.

**Uniformity Gradient** The ratio between any two adjacent illuminance values on the field. A maximum ratio is specified.





**Iowa high School Athletic Association**

IHSAA

P.O. Box 10

Boone, Iowa 50036-0010

Phone: 515/432-2011

Fax: 515/432-2961

[www.iahsaa.org](http://www.iahsaa.org)